



TECNICHE DI CONTROLLO E DIAGNOSI

Diagnosi Automatica dei Guasti

Presenter: Dott. Ing. SIMANI SILVIO

con supporto del Dott. Ing. MARCELLO BONFE'

Lecture Main Topics



- General introduction
 - State-of-the-art review
 - Fault diagnosis nomenclature
- Main methods for fault diagnosis
 - Parameter estimation methods
 - Observer and filter approaches
 - Parity relations
- Application examples
- Concluding remarks

Nomenclature



1. *States and Signals*

Fault

An unpermitted deviation of at least one characteristic property or parameter of the system from the acceptable, usual or standard condition.

Failure

A permanent interruption of a system's ability to perform a required function under specified operating conditions.

Malfunction

An intermittent irregularity in the fulfilment of a system's desired function.

Error

A deviation between a measured or computed value of an output variable and its true or theoretically correct one.

Nomenclature (cont'd)



2. *Functions*

Fault detection

Determination of faults present in a system and the time of detection.

Fault isolation

Determination of the kind, location and time of detection of a fault. Follows fault detection.

Fault identification

Determination of the size and time-variant behaviour of a fault. Follows fault isolation.

Fault diagnosis

Determination of the kind, size, location and time of detection of a fault. Follows fault detection. Includes fault detection and identification.

Monitoring

A continuous real-time task of determining the conditions of a physical system, by recording information, recognising and indication anomalies in the behaviour.

Supervision

Monitoring a physical and taking appropriate actions to maintain the operation in the case of fault.

Introduction

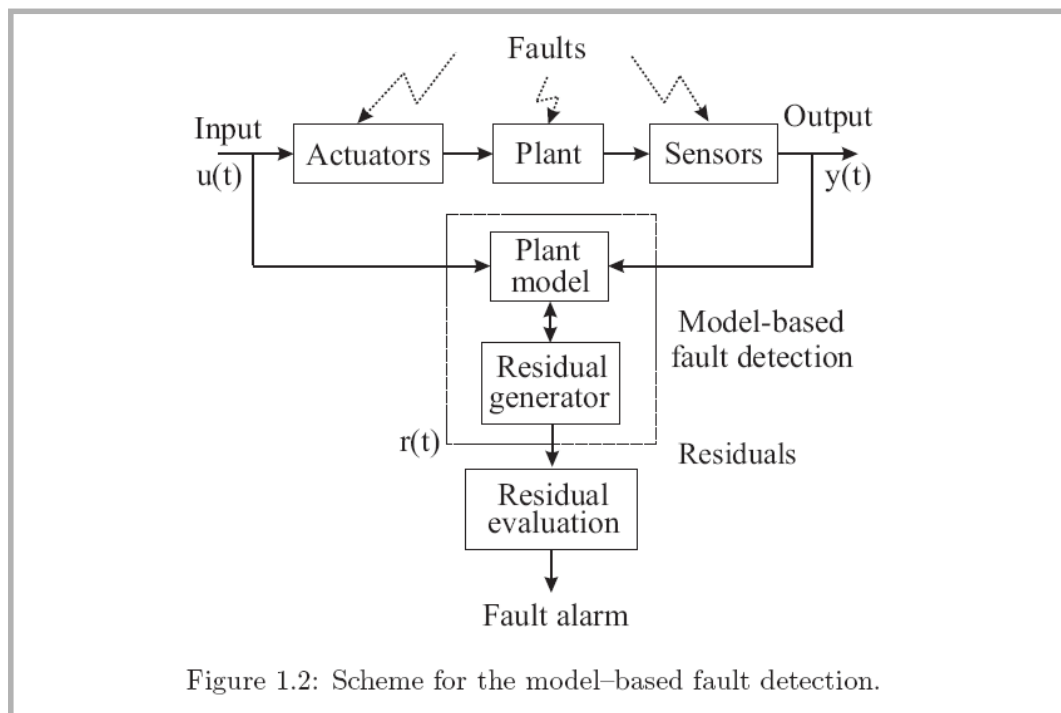

5

Diagnosi Automatica dei Guasti

Residual Generation

- This block generates residual signals using available inputs and outputs from the monitored system
- This residual (or fault symptom) should indicate that a fault has occurred
- Normally zero or close to zero under no fault condition, whilst distinguishably different from zero when a fault occurs

6

Diagnosi Automatica dei Guasti

Residual Evaluation

- This block examines residuals for the likelihood of faults and a decision rule is then applied to determine if any faults have occurred
- It may perform a simple threshold test (geometrical methods) on the instantaneous values or moving averages of the residuals
- It may consist of statistical methods, e.g., generalised likelihood ratio testing or sequential probability ratio testing

Introduction (cont'd)

➡ Model-Based FDI Methods:

1. Output observers (OO, estimators, filters);
2. Parity equations;
3. Identification and parameter estimation.

Model-based FDI Techniques

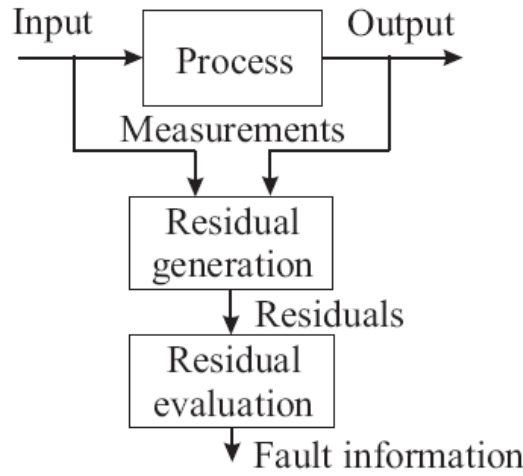

Figure 2.1: Structure of model-based FDI system.

Model-based FDI Techniques (cont'd)

1. **Residual generation:** this block generates residual signals using available inputs and outputs from the monitored system. This residual (or fault symptom) should indicate that a fault has occurred. It should normally be zero or close to zero under no fault condition, whilst distinguishably different from zero when a fault occurs. This means that the residual is characteristically independent of process inputs and outputs, in ideal conditions. Referring to Figure 2.1, this block is called *residual generation*.
2. **Residual evaluation:** This block examines residuals for the likelihood of faults and a decision rule is then applied to determine if any faults have occurred. The *residual evaluation* block, shown in Figure 2.1, may perform a simple threshold test (geometrical methods) on the instantaneous values or moving averages of the residuals. On the other hand, it may consist of statistical methods, *e.g.*, generalised likelihood ratio testing or sequential probability ratio testing [Isermann, 1997, Willsky, 1976, Basseville, 1988, Patton et al., 2000].

Model-based FDI Techniques (cont'd)

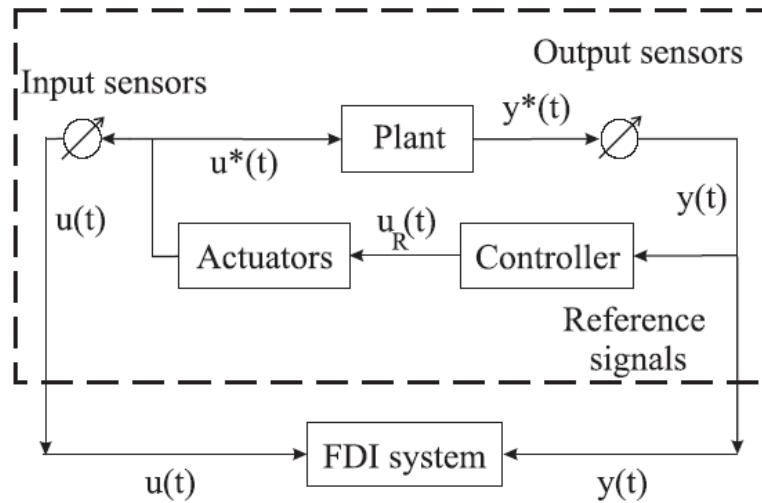

Figure 2.3: The rearranged fault diagnosis scheme.

11

Diagnosi Automatica dei Guasti

Model-based FDI Techniques (cont'd)

Fault Location:

- Actuators
- Process or system components
- Input sensors
- Output sensors
- Controllers

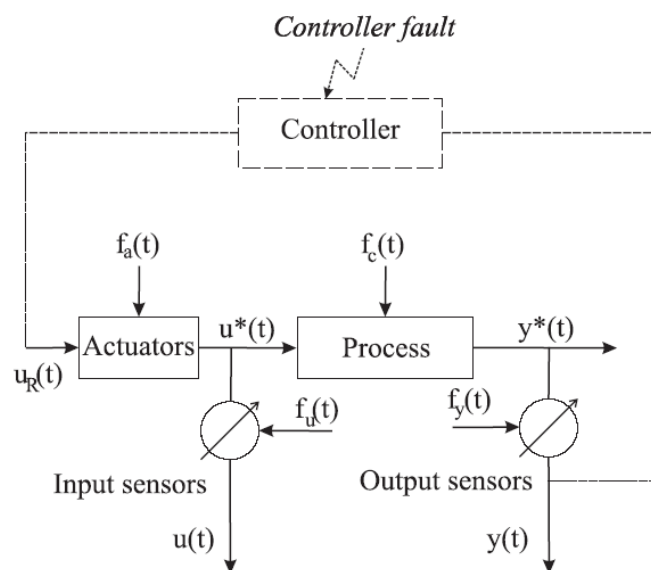

Figure 2.4: The controlled system and fault topology.

12

Diagnosi Automatica dei Guasti



Fault and System Modelling

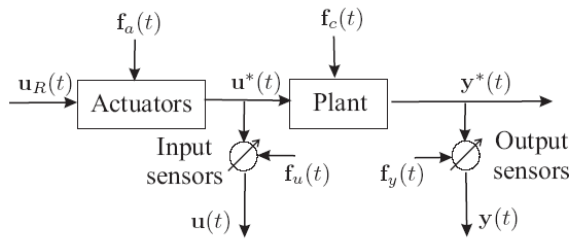

Figure 2.5: The monitored system and fault topology.

$$\begin{aligned}
 \mathbf{x}(t + 1) &= \mathbf{A}\mathbf{x}(t) + \mathbf{B}\mathbf{u}^*(t) + \mathbf{f}_c(t) \\
 \mathbf{f}_c(t) &= I_i \Delta a_{ij} x_j(t) \\
 \begin{cases} \mathbf{u}(t) &= \mathbf{u}^*(t) + \mathbf{f}_u(t) \\ \mathbf{y}(t) &= \mathbf{y}^*(t) + \mathbf{f}_y(t) \end{cases}
 \end{aligned}$$

$$\begin{cases} \mathbf{x}(t + 1) &= \mathbf{A}\mathbf{x}(t) + \mathbf{B}\mathbf{u}^*(t) \\ \mathbf{y}^*(t) &= \mathbf{C}\mathbf{x}(t) \end{cases}$$



Fault and System Modelling

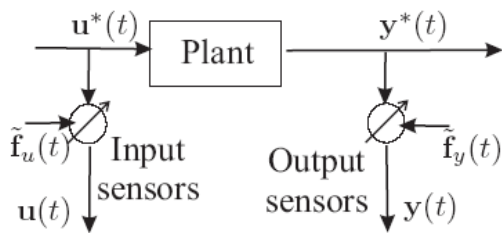
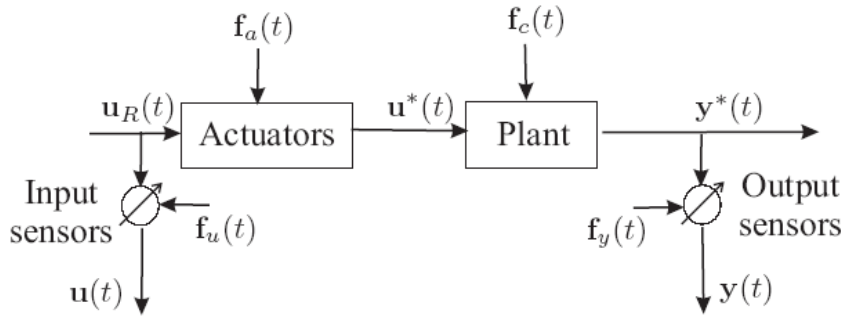

Figure 2.6: The structure of the plant sensors.

$$\begin{aligned}
 \begin{cases} \mathbf{u}(t) &= \mathbf{u}^*(t) + \tilde{\mathbf{u}}(t) \\ \mathbf{y}(t) &= \mathbf{y}^*(t) + \tilde{\mathbf{y}}(t) \end{cases} \\
 \begin{cases} \mathbf{u}(t) &= \mathbf{u}^*(t) + \tilde{\mathbf{u}}(t) + \mathbf{f}_u(t) \\ \mathbf{y}(t) &= \mathbf{y}^*(t) + \tilde{\mathbf{y}}(t) + \mathbf{f}_y(t) \end{cases}
 \end{aligned}$$



Fault and System Modelling



$$u^*(t) = u_R(t) + f_a(t)$$

$$\begin{cases} x(t+1) &= Ax(t) + f_c(t) + Bu^*(t) \\ y(t) &= Cx(t) + f_y(t) \\ u(t) &= u^*(t) + f_u(t) \end{cases}$$

Model-based FDI Techniques (cont'd)



Modelling of Faulty Systems

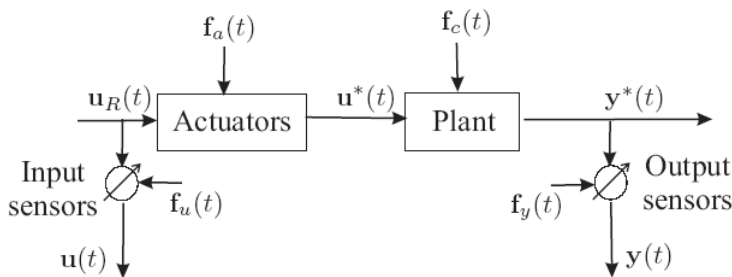
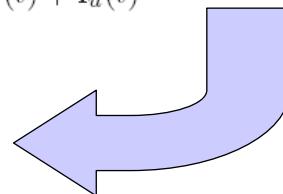

Figure 2.7: Fault topology with actuator input signal measurement.

$$f(t) = [f_a^T, f_u^T, f_c^T, f_y^T]^T \in \mathbb{R}^k$$

$$\begin{cases} x(t+1) &= Ax(t) + f_c(t) + Bf_a(t) + Bu^*(t) \\ y(t) &= Cx(t) + f_y(t) \\ u(t) &= u^*(t) + f_u(t) \end{cases}$$

$$\begin{cases} x(t+1) &= Ax(t) + Bu^*(t) + L_1 f(t) \\ y(t) &= Cx(t) + L_2 f(t) \\ u(t) &= u^*(t) + L_3 f(t) \end{cases}$$



Residual Generator Structure

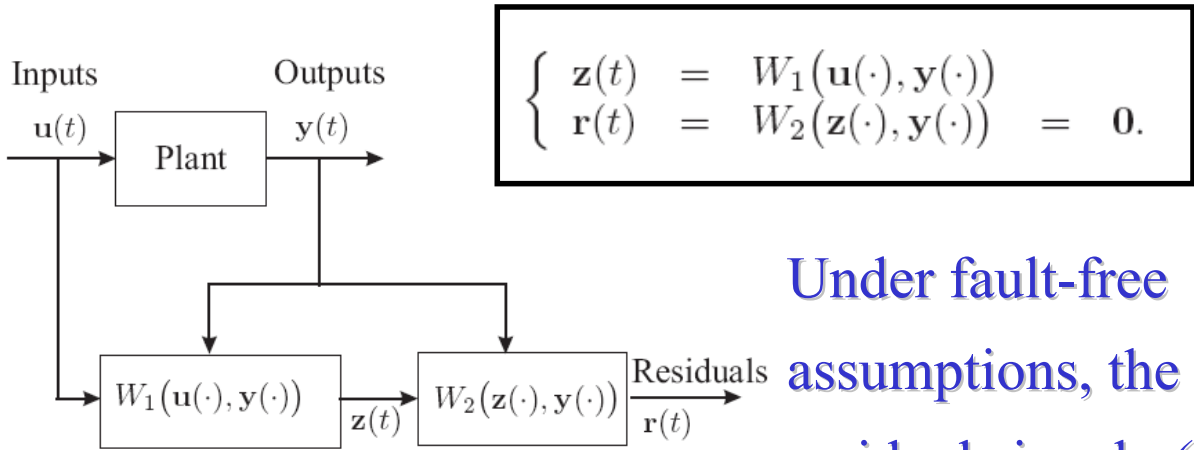

Under fault-free assumptions, the residual signal $r(t)$ is “almost zero”

Figure 2.8: Residual generator general structure.

Residual General Structure (cont'd)

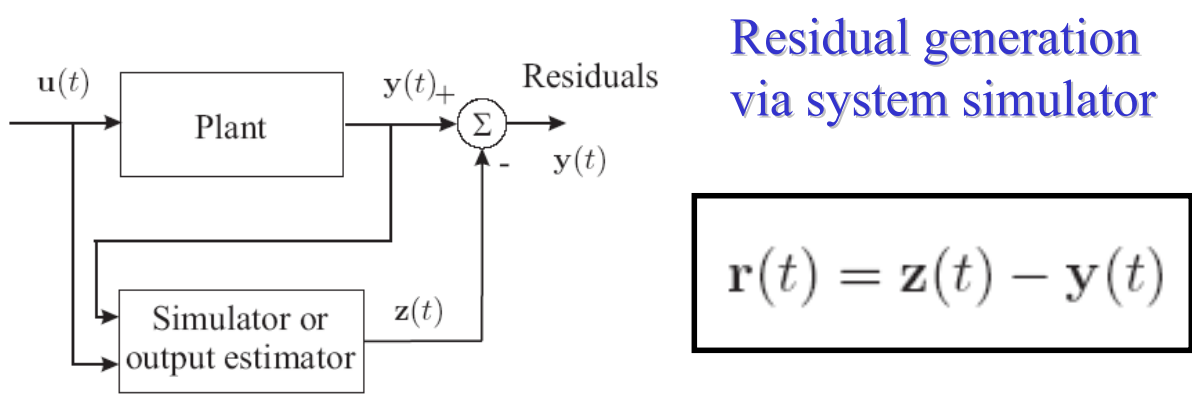

Residual generation via system simulator

$z(t)$ is the simulated plant output

Figure 2.9: Residual generation via system simulator.

General Residual Evaluation



$$\begin{cases} J(\mathbf{r}(t)) \leq \varepsilon(t) & \text{for } \mathbf{f}(t) = \mathbf{0} \\ J(\mathbf{r}(t)) > \varepsilon(t) & \text{for } \mathbf{f}(t) \neq \mathbf{0} \end{cases}$$

Detection thresholds $\varepsilon(t)$

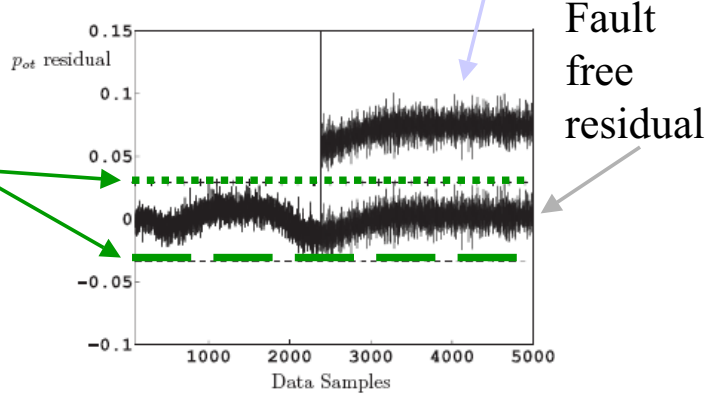

General Residual Evaluation (example)



Detection thresholds

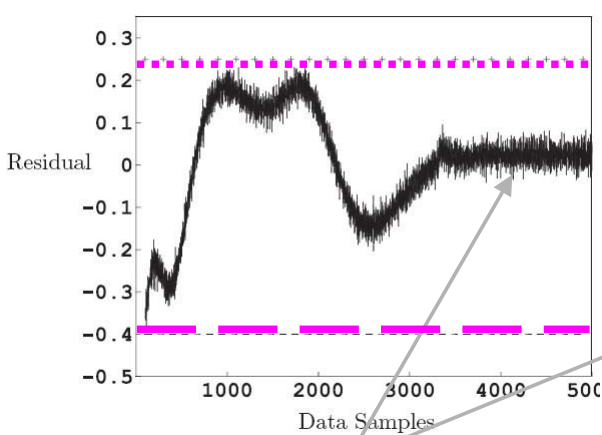

Fault free residual

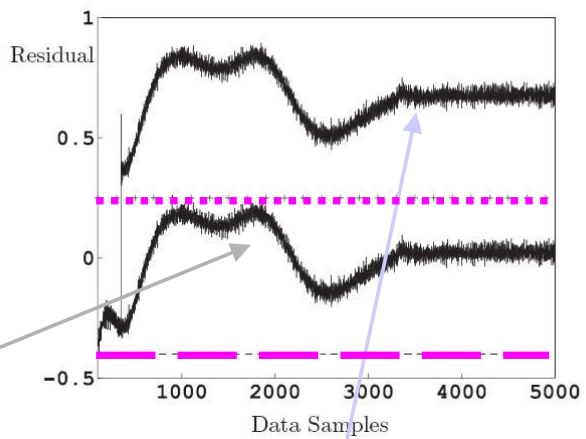

Fault-free & faulty residuals



- Fault detection via parameter estimation
- **Observer-based approaches**
- Parity (vector) relations

Parameter Estimation



- Parameter estimation for fault detection
- The process parameters are not known at all, or they are not known exactly enough. They can be determined with parameter estimation methods
- The basic structure of the model has to be known
- Based on the assumption that the faults are reflected in the physical system parameters
- The parameters of the actual process are estimated on-line using well-known parameter estimations methods

Parameter Estimation (cont'd)



- ➡ The results are thus compared with the parameters of the reference model obtained initially under fault-free assumptions
- ➡ Any discrepancy can indicate that a fault may have occurred



Observer-based Approaches

Residual General Structure



Observer-based approach

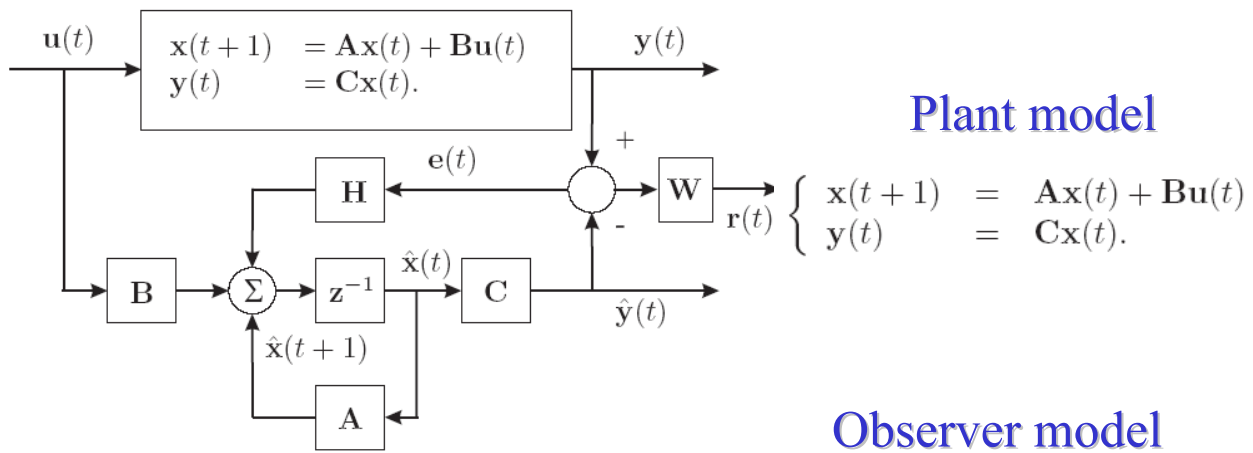

Output estimation approach!

Residual Generator Structure



Plant model

$$\begin{cases} x(t+1) = Ax(t) + Bu(t) \\ y(t) = Cx(t). \end{cases}$$

Observer model

$$\begin{cases} \hat{x}(t+1) = A\hat{x}(t) + Bu(t) + He(t) \\ e(t) = y(t) - C\hat{x}(t). \end{cases}$$

State estimation model

$$\begin{cases} e_x(t) = x(t) - \hat{x}(t) \\ e_x(t+1) = (A - HC)e_x(t). \end{cases}$$

State estimation property

$$\lim_{t \rightarrow \infty} e_x(t) = 0 \quad \text{(fault-free case!!!)}$$

Residual Generator Property



+ disturbance signals and fault

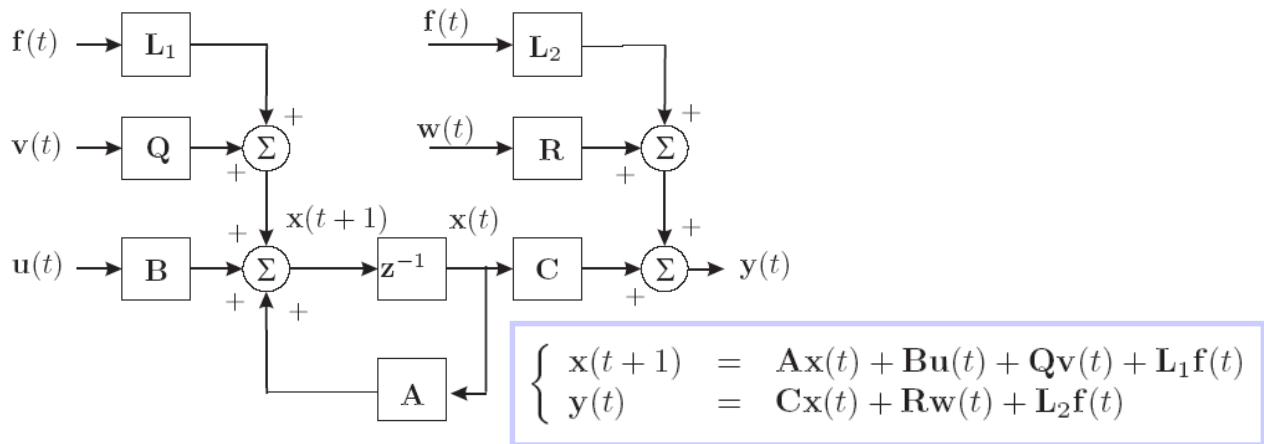

Figure 2.14: MIMO process with faults and noises.

Residual Generator Property (cont'd)



+ fault signals

System model $\begin{cases} \mathbf{x}(t+1) &= \mathbf{A}\mathbf{x}(t) + \mathbf{B}\mathbf{u}(t) + \mathbf{Q}\mathbf{v}(t) + \mathbf{L}_1\mathbf{f}(t) \\ \mathbf{y}(t) &= \mathbf{C}\mathbf{x}(t) + \mathbf{R}\mathbf{w}(t) + \mathbf{L}_2\mathbf{f}(t) \end{cases}$

Observer model $\mathbf{e}_x(t+1) = (\mathbf{A} - \mathbf{H}\mathbf{C})\mathbf{e}_x(t) + \mathbf{L}_1\mathbf{f}(t) - \mathbf{H}\mathbf{L}_2\mathbf{f}(t)$

Output estimation error
with faults *but noise-free*

$$\mathbf{e}(t) = \mathbf{C}\mathbf{e}_x(t) + \mathbf{L}_2\mathbf{f}(t).$$

Both $\mathbf{e}(t)$ and $\mathbf{e}_x(t)$ are suitable residuals!

General Residual Evaluation

$$\begin{cases} J(\mathbf{r}(t)) \leq \varepsilon(t) & \text{for } \mathbf{f}(t) = \mathbf{0} \\ J(\mathbf{r}(t)) > \varepsilon(t) & \text{for } \mathbf{f}(t) \neq \mathbf{0} \end{cases}$$

Detection thresholds
 $\varepsilon(t)$

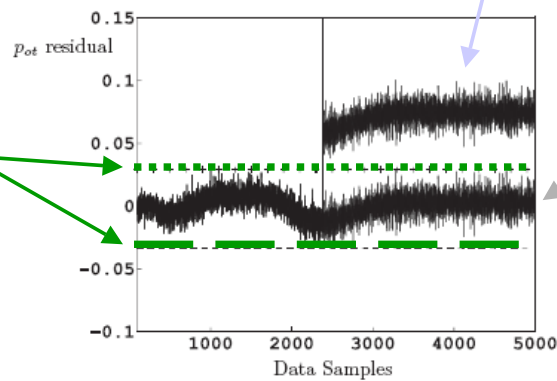

Faulty residual

Fault free residual

Change Detection & Residual Evaluation

$$\begin{cases} J(\mathbf{r}(t)) \leq \varepsilon(t) & \text{for } \mathbf{f}(t) = \mathbf{0} \\ J(\mathbf{r}(t)) > \varepsilon(t) & \text{for } \mathbf{f}(t) \neq \mathbf{0} \end{cases}$$

$$J(r(t)) \equiv |r(t)|$$

Detection thresholds
 $\varepsilon(t)$

$$\bar{r}_i = E\{r_i(t)\}; \quad \bar{\sigma}_i^2 = E\{[r_i(t) - \bar{r}_i]^2\}$$

$$\varepsilon(t) = \bar{r}_i \pm \delta \times \bar{\sigma}_i \quad (i = 1, \dots, m)$$

with $\delta \geq 3$

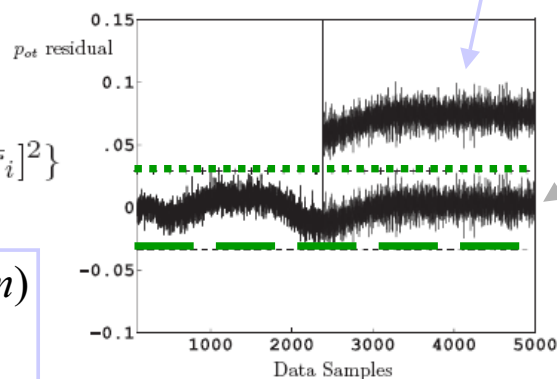

Faulty residual

Fault free residual

Residual Generation

- ✓ Output Observers
- Unknown Input Observers
- ✓ Fault Detection

❖ *Fault Isolation, i.e. where is the fault?*

Output Observer

Process model with faults

$$\begin{aligned} \mathbf{x}(t+1) &= \mathbf{A}\mathbf{x}(t) + \mathbf{B}(\mathbf{u}(t) + \mathbf{f}_c(t)) + \mathbf{f}_s(t) \\ \mathbf{y}(t) &= \mathbf{C}\mathbf{x}(t), \end{aligned}$$

Input-output sensor faults

$$\left. \begin{aligned} \mathbf{u}(t) &= \mathbf{f}_u(t) + \mathbf{u}^*(t) \\ \mathbf{y}(t) &= \mathbf{f}_y(t) + \mathbf{y}^*(t) \end{aligned} \right\}$$

Observer for the i -th output $y_i(t)$

$$\mathbf{x}^i(t+1) = \mathbf{A}_i\mathbf{x}^i(t) + \mathbf{B}_i\mathbf{u}(t) + \mathbf{K}_i(y_i(t) - \mathbf{C}_i\mathbf{x}^i(t))$$

$(\mathbf{A}_i, \mathbf{B}_i, \mathbf{C}_i)$ is the state-space process model

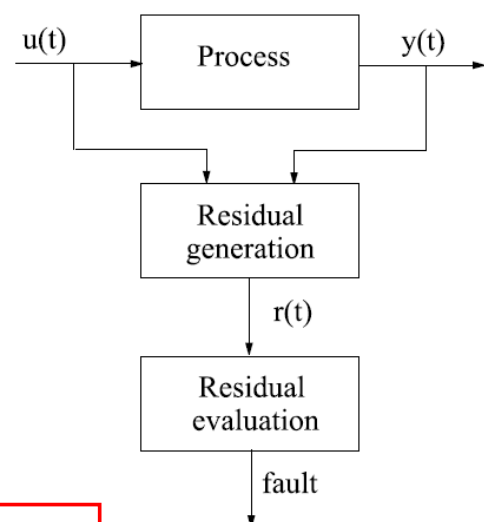

Output Observer for *Fault Detection*

Given the observer model

$$\mathbf{x}^i(t+1) = \mathbf{A}_i \mathbf{x}^i(t) + \mathbf{B}_i \mathbf{u}(t) + \mathbf{K}_i (y_i(t) - \mathbf{C}_i \mathbf{x}^i(t))$$

Under fault-free assumptions

$$r_i(t) = y_i^*(t) - \hat{y}_i(t) = \mathbf{C}_i (\mathbf{x}_i(t) - \mathbf{x}^i(t)) \text{ is equal to zero.}$$

Fault detection logic

fixed threshold ϵ ,

$$\left. \begin{array}{l} \mathbf{r}(t) \leq \epsilon \text{ for } \mathbf{f}(t) = \mathbf{0} \\ \mathbf{r}(t) > \epsilon \text{ for } \mathbf{f}(t) \neq \mathbf{0} \end{array} \right\}$$

$\mathbf{f}(t)$ being a generic failure vector.

Output Observer for *Fault Isolation*

$$\left. \begin{array}{l} \mathbf{x}(t+1) = \mathbf{A}\mathbf{x}(t) + \mathbf{B}\mathbf{u}(t) + \mathbf{B}\mathbf{f}_u(t) \\ \mathbf{y}(t) = \mathbf{C}\mathbf{x}(t) + \mathbf{f}_y(t) \end{array} \right\}$$

Process model

$$\mathbf{x}^i(t+1) = \mathbf{A}_i \mathbf{x}^i(t) + \mathbf{B}_i \mathbf{u}(t) + \mathbf{K}_i (y_i(t) - \mathbf{C}_i \mathbf{x}^i(t))$$

$$r_i(t) = y_i^*(t) - \hat{y}_i(t) = \mathbf{C}_i (\mathbf{x}_i(t) - \mathbf{x}^i(t))$$

$$y_i(t) = y_i^*(t) + f(t)$$

Bank of output observers

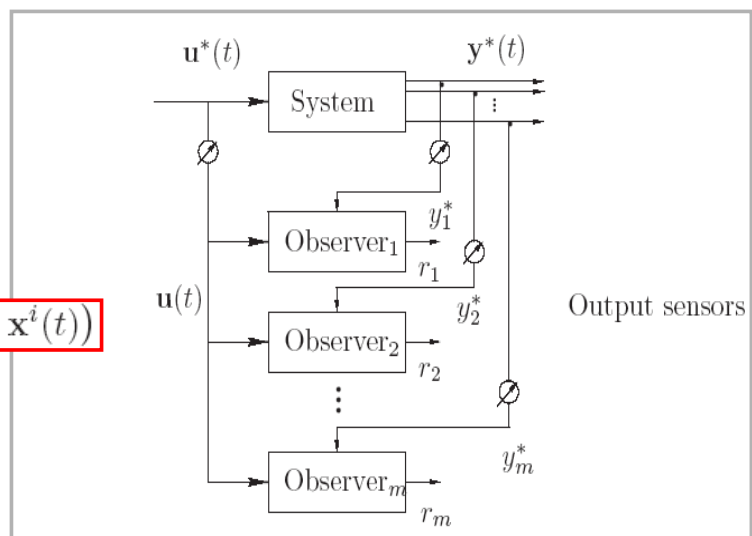

Output Observer for *Fault Isolation* (cont'd)

$$\mathbf{x}^i(t+1) = \mathbf{A}_i \mathbf{x}^i(t) + \mathbf{B}_i \mathbf{u}(t) + \mathbf{K}_i (y_i(t) - \mathbf{C}_i \mathbf{x}^i(t))$$

$$r_i(t) = y_i^*(t) - \hat{y}_i(t) = \mathbf{C}_i (\mathbf{x}_i(t) - \mathbf{x}^i(t))$$

Fault-free case:

$$\lim_{t \rightarrow \infty} r_i(t) = \lim_{t \rightarrow \infty} (y_i(t) - \mathbf{C}^i \mathbf{x}^i(t)) = 0$$

Faulty case

$$y_i(t) = y_i^*(t) + f(t)$$

Bank of output observers

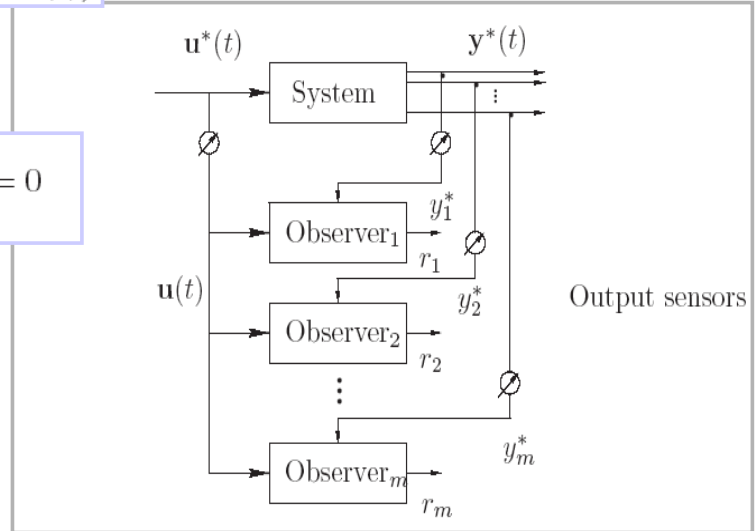

35

Diagnosi Automatica dei Guasti

Residual Disturbance Robustness

- ➔ Residuals decoupled from disturbance
- ➔ Robust residual generator
- ➔ Disturbance effect minimisation
- ➔ Measurement errors

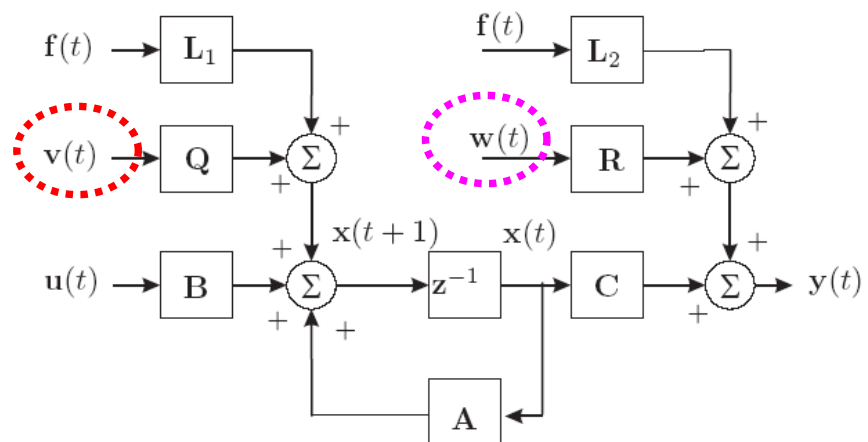

Figure 2.14: MIMO process with faults and noises.

36

Diagnosi Automatica dei Guasti

FDI with Noisy Measurements

$$\begin{cases} \mathbf{x}(t+1) &= \mathbf{A}\mathbf{x}(t) + \mathbf{B}\mathbf{u}(t) + \mathbf{Q}\mathbf{v}(t) + \mathbf{L}_1\mathbf{f}(t) \\ \mathbf{y}(t) &= \mathbf{C}\mathbf{x}(t) + \mathbf{R}\mathbf{w}(t) + \mathbf{L}_2\mathbf{f}(t) \end{cases}$$

✓ Model with fault and noise

$$\begin{cases} \mathbf{x}(t+1) &= \mathbf{A}\mathbf{x}(t) + \mathbf{B}\mathbf{u}(t) + \mathbf{Q}\mathbf{v}(t) \\ \mathbf{y}(t) &= \mathbf{C}\mathbf{x}(t) + \mathbf{R}\mathbf{w}(t) \end{cases}$$

➤ Model with noise only: Kalman filter!

Kalman Filter Properties (cont'd)

➤ Defined:

- It minimises: $e(t) = x(t) - \hat{x}(t)$
- *i.e.* the mean square error & the error covariance matrix $E[e^T(t)e(t)] \equiv P(t)$

➤ Filter gain $K(t)$

- Solution of the difference equation:

$$P(t+1) = -AP(t)C^T [R + CP(t)C^T]^{-1} CP(t)A^T + AP(t)A + Q$$



Fault Detection with Parity Equations

Parity Relations for Fault Detection



- ➡ The basic idea of the parity relations approach is to provide a proper check of the parity (consistency) of the measurements acquired from the monitored system
- ➡ In the early development of fault diagnosis, the parity vector (relation) approach was applied to static or parallel redundancy schemes, which may be obtained directly from measurements (**hardware redundancy**) or from analytical relations (**analytical redundancy**)

- 
- In the case of **hardware redundancy**, two methods can be exploited to obtain redundant relations
 - The first requires the use of several sensors having identical or similar functions to measure the same variable
 - The second approach consists of dissimilar sensors to measure different variables but with their outputs being relative to each other

➤ **Analytical forms of redundancy**



Fault Diagnosis Technique Integration

FDI Technique Integration

- ➡ Several FDI techniques have been developed and their application shows different properties with respect of the diagnosis of different faults in a process
- ➡ To achieve a reliable FDI technique, a good solution consists of a proper integration of several methods which take advantages of the different procedures
- ➡ Exploit a knowledge-based treatment of all available analytical and heuristic information

43

Diagnosi Automatica dei Guasti

Residual Generation via Heuristic Models

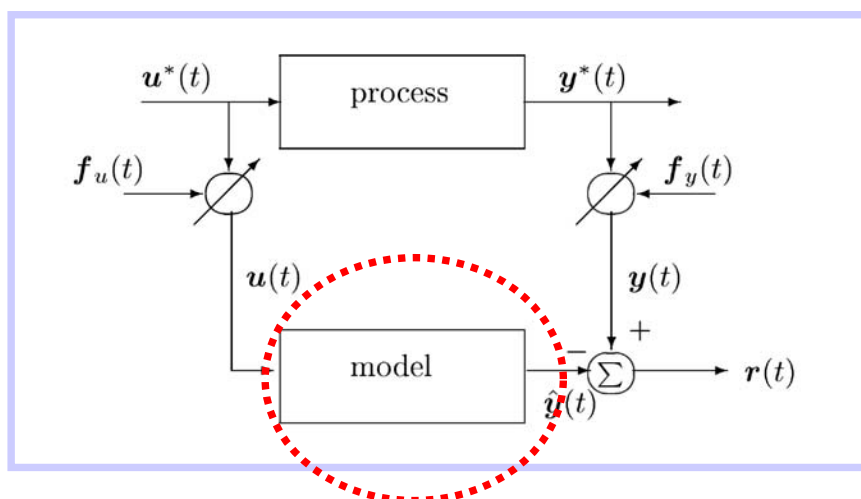

Residual signals: $r(t) = y(t) - \hat{y}(t)$.

Model: fuzzy system or neural network!!!

44

Diagnosi Automatica dei Guasti